

NX-dsPIC30F

dsPIC30F microcontroller Experiment board

Specification

- Supports Microchip's dsPIC microcontroller in DIP-28 and 40 pins package. On-board has dsPIC30F2010 on 28-pin socket. About 40-pin socket can support dsPIC30F4011 (microcontroller chip is optional)
- Debugging and Programming with INEX's ICDX-30 or Microchip's ICD2 (Sold separated)
- Mode select (RIN and PROG) by a push switch with indicator. This experiment board will separate 2 parts of dsPIC socket. Experimenter can test both dsPIC microcontroller in same time if require.
- 7.3728MHz clock for 28-pin dsPIC and 4MHz for 40-pin dsPIC
- Provides all port pin of dsPIC microcontroller
- +5V and GND supply connector
- Two RESET switch for dsPIC microcontroller both version
- 8-LED monitor with limit current resistor. Active logic "1"
- 4-Button switch with pull-up resistor. Active logic "0"
- Two of RS-232 serial port interface circuit.
- Piezo speaker
- LCD interface connector with brightness adjustment
- Four of 0-5V Variable analog source for Analog to Digital Converter
- Pulse generator 1Hz, 10Hz, 100Hz and 1kHz selected by push-switch with indicator
- 800-points Breadboard
- Need +9V to +16V from external DC adaptor

Packing List

- Experiment board
- Documentation
- 16x2 LCD module
- RS-232 serial port cable
- Wire jumper box set

1. Schematic of NX-dsPIC30F experiment board

Figure 1 is complete schematic of NX-dsPIC30F experiment board. The dsPIC microcontroller is provided a dsPIC30F2010 on 28-pin socket. Addition this experiment board provide a blank 40-pin socket for support dsPIC microcontroller 40-pin version.

On the NX-dSPIC30F expeiment board provides 2 units of Microcontroller circuit, 28 and 40-pin. Each circuit has a Mode selection switch with indicator, a RESET switch and all microcontroller port pin in the female expeiment connector. Experimenters can use 2 units together.

In programming, need external programming tools such as ICD2 from Microchip or ICDX-30 In-circuit Debugger and PX-800 Programmer from Innovative Expeiment via RJ-11 jack ICD2 pin compattible.

The NX-dSPIC30F contains many experiment tools include :

(1) **LED monitor** : 8-channel provides on this experiment board. Active with Logic "1" and have limit current resistor.

(2) **LCD interface connector** : on board prepares 14-pin IDC connector for connecting LCD with femle connector and ribbon wires. This connector can support Character LCD 16 to 20 characters 1 and 2 line. Complete with 10k Ω variable resistor for BRIGHTNESS adjustment of LCD

(3) **Piezo speaker** : connected 10mF capacitor in series for coupling the signal to drive. A piezo speaker has itself resonance frequency. Normally is 2 to 3kHz. But in another frequency this speaker can drive but low loud.

(4) **Switch input** : provides 4 sets of push-button switch with pull-up resistor. If switch is not pressed, logic output is "1". If switch is pressed, logic output is "0". Expeimenter can use this switch to Simple Single pulse generator

(5) **Pulse generator** : provides a selectable square-wave output of 1 Hz, 10 Hz, 100 Hz, and 1 kHz. Frequency selection is by the push-button near the pulse generator output (an LED indicates current frequency). Be sure that the output of the pulse generator is connected to an input pin only, as this output is driven both high and low.

(6) **DC motor driver** : use L293D, the H-Bridge driver IC to drive 2-channel of DC motor. Each channel need 3-pin signal to control. For motor #1, use 12EN pin and 34EN pin for motor #2. This circuit has bi-color LED for motor pole supply. If correct, LED will light GREEN. If swap, LED will lights RED. Supply voltage for L293D is approximate +12V from main DC adaptor. This ciruit can drive motor 6-12V 300mA.

(7) **12-Bit Digital to Analog Converter** : this experiment board offer 2-Ch. 12-bit Digital to Analog Converter IC, MCP4922 from Microchip. It cn control via SPI.

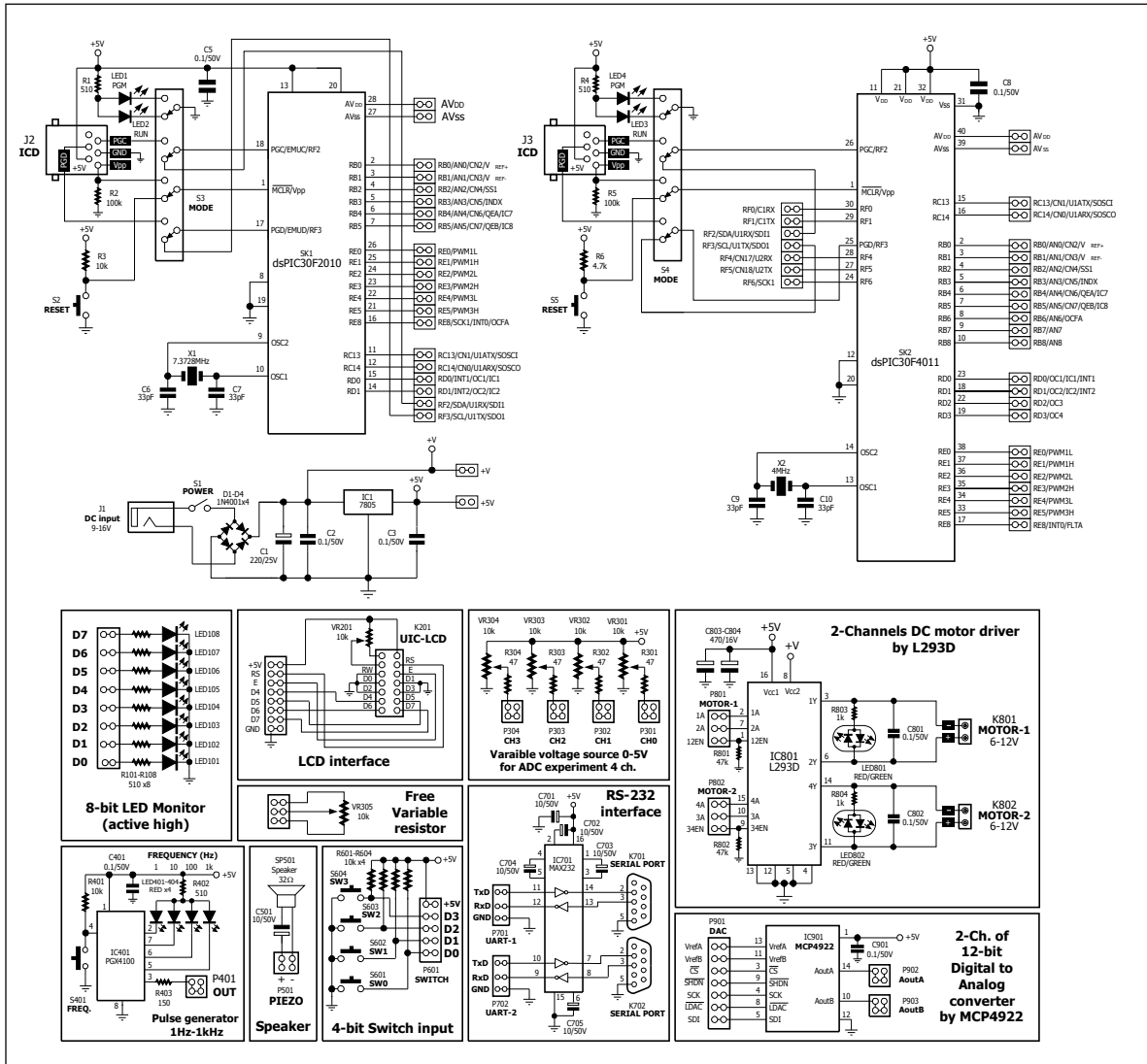

Figure 1 NX-dsPIC30F dsPIC Microcontroller Experiment board

(8) **0 to +5V Reference Voltage Source** : for support analog experiment, NX-dSPIC30F experiment board provides 4 channels of 0 to 5V analog voltage source to supply analog voltage for ADC circuit purpose only.

(9) **RS-232 Serial port interface** : The NX-dsPIC30F provides 2 of RS-232 serial port interface circuit. Use MAX232 IC for this circuit and female DB-9 connector to interfacing

(10) **The Solderless Breadboard** : Most experiments will involve components placed in the solderless breadboard. The breadboard on this experiment board size is 2.5x7 Inches and provides 800 point-contacts.

2. Using experiment board

2.1 Preparation

Before using, user must prepare some tool and software following :

1. Personal computer which install Window 98SE/ME/2000/XP, text editor program, MPLAB V6.61 or higher and MPLAB C 30 compiler

MPLAB V6.61 and **MPLAB C30 compiler** are licenced by Microchip Technology , for more information please contact at <http://www.microchip.com>

Computer must has at least one serial port if use ICDX-30 and/or USB port for connect with Microchip's ICD2 and PX-800 Programmer.

2. Write program with MPLAB and compile with MPLAB C30. See the procedure from software manual. The output file is HEX file.

3. Prepare DC adpator 9-16V 500mA.

2.2 Procedure

- (1) Constuct the curcuit on breadboard on NX-dsPIC30F board.
- (2) Connect the hardware of programming tools to computer.
- (3) Connect ICSP cable from ICD2 or ICDX-30 or PX-800 to NX-dsPIC30F board.
- (4) Supply voltage to NX-877 plus board.
- (5) Press MODE switch for changing to PROGRAM mode, red LED is bright.
- (6) Select number of dsPIC microcontroller depend on the chip that install on experiment board.
- (7) Open HEX file.
- (8) Erase and blank check data in microcontroller.
- (9) Program data into microcontroller
- (10) Verify programming
- (11) After programming completed, press MODE switch to RUN mode. Microcontroller will run your program.

Optional :

- **ICD2** Debugger/Programmer tool for PIC/dsPIC microcontroller
- **ICDX-30** Debugger/Programmer board for PIC/dsPIC microcontroller with DC adaptor (ICD2 compatible but only work with RS-232 serial port)
- **PX-800** USB- PIC/dsPIC Programmer

