

JX-dsPIC40

40-pin dsPIC microcontroller Project board

Features

- Use a 40-pin DIP dsPIC30F device, **dsPIC30F4011** on-board Clock rate of 4MHz
- Debugging and programming via LCD jack with ICDX-30 or ICD2 (optional)
- Select PROG and RUN mode with a switch.
- Prepare 5-ports as : *RB0-RB8, RC13-RC14, RD0-RD3, RE0-RE5, RE8 and RF0-RF6*
- +5V 800mA regulated DC supply on-board
- RESET switch
- LCD modul connection : D4-D7 with RD0-RD3, RS with RF0 and E with RF1 port pin.
- 2 of RS-232 serial port interface
 - UART1 connect with RC13 and RC14, selected by jumper
 - UART2 connect with RF4 and RF5, selected by jumper
- Free experimental device as :
 - 4-LED monitor active logic "high"
 - Piezo speaker
 - 4-Push button switches with pull-up resistors
 - 4-points Terminal block for connect with QEI (Quadrature Encoder Input)
 - 0-5V reference source for A/D testing
- Proto area 3x2.5 Inches with 170 solder pads. This area support medium size breadboard (KH-102 from K&H)
- Required +9Vdc 500mA supply (up to +12Vdc)

Packing List

- Experiment board
- Documentation

Optional :

- +12V 500mA DC adapter
- ICDX-30 Debugger/Programmer for PIC/dsPIC with DC adapter
- RS-232 serial port cable

1. JX-dsPIC40 schematic diagram

Figure 1 is complete schematic diagram of JX-dsPIC40 project board. The dsPIC chip on-board is dsPIC30F4011. It has 29 input/output port pins.

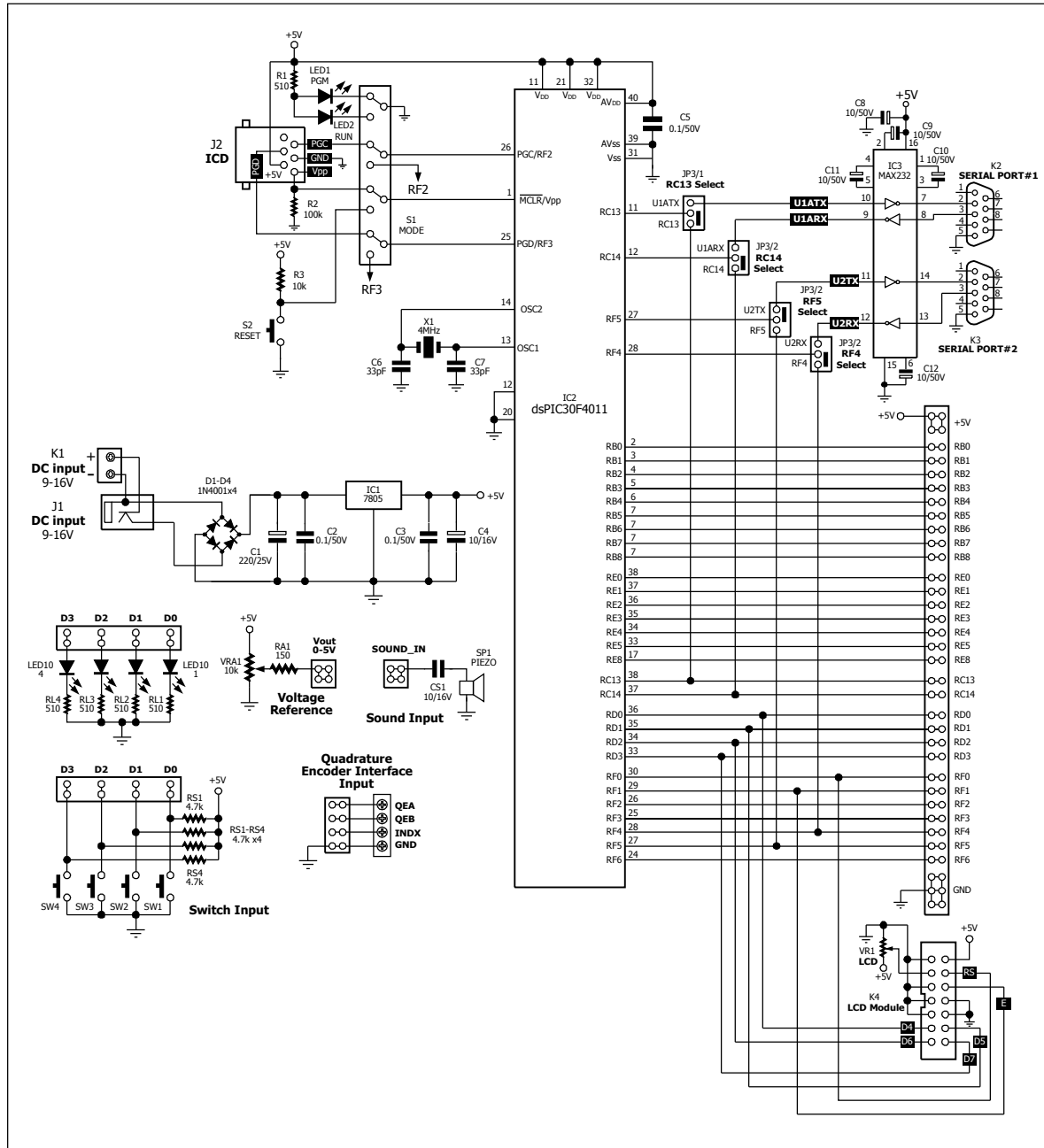

Figure 1 JX-dsPIC40 Project board schematic diagram

2. Develop procedure

1. Install software development include MPLAB V6.2 or higher (suggest V6.61) and MPLAB C30 for C language programming.

2. Must use JX-dsPIC40 board with Microchip's ICD2 or INEX's ICDX-30 debugger/programmer board

3. Construct the circuit on the prototype area on JX-dsPIC28 project board.

4. Make the program on MPLAB then compile to HEX file.

5. Connect ICD2 or ICDX-30 with JX-dsPIC40 project board.

6. Apply the supply voltage to these boards. Select MODE switch on JX-dsPIC40 to PROGRAM mode. Download HEX file into dsPIC chip. Select MODE switch again to RUN mode and test the operation.

3. How to test the JX-dsPIC40 project board

Normally, all JX-dsPIC40 project boards must pass the testing by maker before ship to all customers. However user can test by an example program in C language, test_jxdspic40.c. This file need a library file, lcd4011.h. All file can download from www.inexglobal.com. Write or open that file with MPLAB and Build Project.

Connect ICD2 or ICDX-30 with JX-dsPIC40 project board and apply the supply voltage to all boards. Select MODE switch on JX-dsPIC40 to PROGRAM mode. Download HEX file into dsPIC chip.

Testing #1 : Construct circuit and write the code

File : test_jxdspic40.c (must include lcd4011.h library file)

Download from www.inexglobal.com

1.1 Connect LCD module to LCD port on JX-dsPIC40 board.

1.2 **Connect the Push button #0 to RF6 pin for MODE selection ; Menu : 1 to Menu : 5.** The message will show on LCD

1.3 **Connect the Push button #1 to RF3 for ENTER or ESC testing selection.**

1.4 Open MPLAB that install MPLAB C30 ready. Make project and compile. The result hex file is test_jxdspic40.hex (all C source program and library can download from www.inexglobal.com)

1.5 Apply the supply voltage to all boards.

1.6 Program the hex file to dsPIC30F4011 chip on JX-dsPIC40 board. Press RESET switch to run the program.

Testing #2 : Test menu 1 - Output port testing

2.1 After run the testing program, at LCD show this message :

```
Menu: 1
Digital I/O Test
```

If user would like to test, press the push button switch at RF3 pin (ENTER/ESC) to enter the testing.

2.2 Connect the port undertest to LED on JX-dsPIC40 board. Observe LED blinking except 2 pin ; RF3 and RF6 because both pins are connected to switch. Press the switch at RF3 pin again to exit this testing to main operation.

Testing #3 : Test menu 2 - ADC module

3.1 Press the switch #0 at RF6 pin until LCD show this message :

```
Menu: 2
Analog(RB0-RB8)
```

3.2 Connect the analog input port of dsPIC30F4011 (available 9 channels) to Voltage Reference 0-5V circuit on JX-dsPIC40 board. This example select RB0. Next, press the switch at RF3 pin (ENTER/ESC) to enter this testing.

3.3 At LCD module, it will show :

```
U(RB0) X.XX Volt
<RF3, Esc>
```

Thus, X.XX is Voltage value reading

3.4 Adjust the variable resistor and see the result at LCD.

3.5 User can shift the input channel to other by press the swith at RF3. It is ring counter selection. If the channel is changed must change the wire connection.

3.6 Press the switch at RF3 pin again to exit this testing to main operation.

Testing #4 : Test menu 3 - Sound via Piezo

4.1 Connect RE0 port pin to Piezo speaker on JX-dsPIC40 board.

4.2 Press the switch #0 at RF6 pin until LCD show this message :

```
Menu: 3
Sound Test
```

press the switch at RF3 pin (ENTER/ESC) to enter this testing.

4.3 dsPIC30F4011 chip will generate sound signal and drive to the piezo speaker. LCD will show the warning message below :

```
RE0 Connect to
PIEZO for te.st
```

After that change message to :

```
<RF3, Esc>
```

4.4 Press the switch at RF3 pin again to exit this testing to main operation.

Testing #5 : Test menu 4 - UART1 testing

5.1 Press the switch #0 at RF6 pin until LCD show this message :

```
Menu: 4
UART1 Test
```

5.2 Set JP2 jumper to using U1ATX and U1ARX for UART1 testing.

5.3 Connect the serial cable between computer's RS-232 serial port with DB-9 connector at UART1 position on JX-dsPIC40 board.

5.4 Open the terminal software such as Hyper Terminal. Select 9,600 bps baudrate and format data to 8N1

6 • JX-dsPIC40 project board technical info

5.5 Press the switch at RF3 pin (ENTER/ESC) to enter this testing and LCD will show this message :

```
UART1 Active!  
at 9600 bps
```

5.6 If operation is correct, The terminal will show this message continue :

```
UART1 Active!
```

5.7 Need to exit, press the switch at RF3 pin again. The terminal window will show this message :

```
Exit from UART1
```

Testing #6 : Test menu 5 - UART2 testing

6.1 Press the switch #0 at RF6 pin until LCD show this message :

```
Menu: 5  
UART2 Test.
```

6.2 Set JP1 jumper to using U2ATX and U2ARX for UART2 testing.

6.3 Connect the serial cable between computer's RS-232 serial port with DB-9 connector at UART2 position on JX-dsPIC40 board.

6.4 Open the terminal software such as Hyper Terminal. Select 9,600 bps baudrate and format data to 8N1

6.5 Press the switch at RF3 pin (ENTER/ESC) to enter this testing and LCD will show this message :

```
UART2 Active!  
at 9600 bps
```

6.6 If operation is correct, The terminal will show this message continue :

```
UART2 Active!
```

6.7 Need to exit, press the switch at RF3 pin again. The terminal window will show this message :

```
Exit from UART2
```

